

# UPRIGHT

## IM20



Note: Benches not included  
Optional steam condenser available (see Diagram B)

With European technology this commercial dishwashing machine has been designed for Australian conditions to be an extremely user-friendly and functional pass-through machine. Incorporating a number of technical features such as the smooth lifting hood, large pass-through door entry of 410mm, and a quick start option so when the hood closes this industrial dishwashing machine starts and keeps performing in the busiest of environments.

### FEATURES

- **Warranty – 3 years on the control board, 1 year parts and labour on the remainder of the machine**
- 60 / 120 / 180 / 720 second cycles
- Up to 1000 plates per hour\*
- Automatic detergent injection
- Corner and In-line positioning
- Easy cleaning
- Ergonomically designed
- Heat recovery unit available

- 1 x Flat Rack 500mm x 500mm
- 1 x Cutlery container
- 1 x Drain hose
- 1 x Water connection hose
- 1 x Operating manual

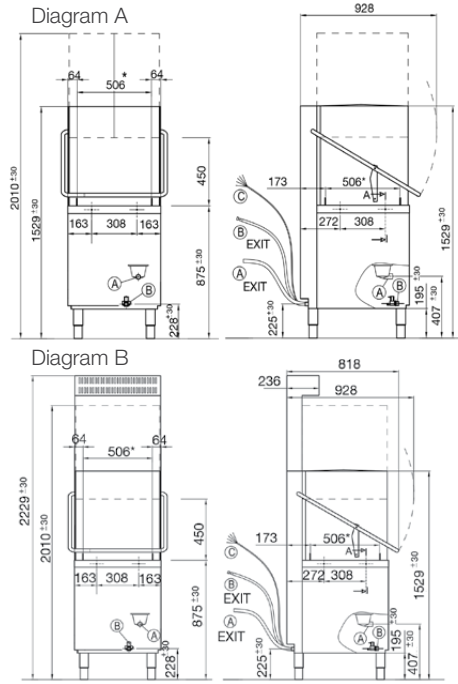

### TECHNICAL DATA

#### Height

|                       |              |
|-----------------------|--------------|
| Cabinet               | 1335 mm      |
| Cabinet inc. legs     | 1500-1560 mm |
| With hood extended    | 1985-2045 mm |
| Usable Wash           | 440 mm       |
| *With steam condenser | 2210-2150 mm |

#### Width

|             |        |
|-------------|--------|
| Cabinet     | 634 mm |
| Inc. handle | 725 mm |

#### Depth

|             |        |
|-------------|--------|
| Cabinet     | 745 mm |
| Inc. handle | 818 mm |

#### Capacities

|                     |           |
|---------------------|-----------|
| Loads/Hour          | up to 40* |
| Water per Cycle     | 2.7L      |
| Wash Pump           | 1100W     |
| Rinse Pump          | 200W      |
| Wash Tank Litres    | 20        |
| Rinse Litres        | 6         |
| Element (wash)      | 3000W     |
| Element (rinse)     | 9500W     |
| Detergent Injection | yes       |
| Rinse Aid Injection | yes       |

#### Temperatures

|                 |       |
|-----------------|-------|
| Wash Degrees C  | 60 °C |
| Rinse Degrees C | 82 °C |

#### Plumbing

|       |                                  |
|-------|----------------------------------|
| Drain | Gravity<br>(Drain Pump Optional) |
| Water | 3/4" BSP (hot)                   |

#### Electrical

|                |               |
|----------------|---------------|
| Volts/Hz/Phase | 400V/50Hz/3+N |
| Amps           | 20Amps/Ph     |

\* Subject to incoming water temperature

